

The COPA Guide to Gliding



2nd Edition – November 2008

Copyright Canadian Owners and Pilots Association 2008

The Canadian Owners & Pilots Association
71 Bank Street – 7th Floor, Ottawa, Ontario K1P 5N2 Canada
Tel: 613-236-4901 • **Fax:** 613-236-8646 • **Email:** copa@copanational.org
Website: www.copanational.org

Contents

Introduction

Section I

Gliders – What are they?

What is a sailplane?

Soaring – what is it?

Gliding - different from power flying?

Gliding Terminology

A Short History of Gliders

Soaring Association of Canada

Gliding locations in Canada

Gliding locations in the USA

The Regulations and Gliders

Licences To Fly Gliders In Canada

Cost of Training

Passenger-Carrying

Section II

Motor Gliders General

Self-Launching

Sustaining

Touring

Transitioning to motorized Gliders

Section III

Glider Cross Country Flying

Section IV

Badge Flying

Contest Flying

Section V

Typical Glider Circuit

Freedoms Wings

Section VI

Becoming a Tow Pilot

Introduction

Soaring has a wide appeal among aviators and many power pilots have been drawn to the sport. Many have joined a gliding club to gain flying experience as a tow pilot and found the allure of motor-less flight too strong to ignore. Somehow the challenge of harnessing mother nature's energy and propelling one's self hundreds of kilometers cross country in silent flight, reminiscent to the challenges sailors must have felt for thousands of years on the sea, brings us back to our roots as aviators. As a power pilot looking at soaring as another avenue to explore you will find many similarities and a few differences to what you have already learned. What you will find similar is the basic operation of a glider to that of a power plane and how the controls affect the flight. The aerodynamics is the same as are the instruments in general and how to interpret them. Power pilots learn to soar quickly.

The aim of this guide is to provide some basic information on gliding and soaring to assist you in deciding if the sport of soaring could interest you.

Section I

Gliders – What are they?

What folks refer to, as a glider is actually a sailplane. Gliders are usually defined as a motorless airplane, and were used extensively in World War Two to transport troops and equipment silently behind enemy lines. A sailplane is always gliding downwards actually, but by using lifting sources, which offset the downward speed of the plane, the sailplane can gain altitude and fly great distances without needing to find lift again. Sailplanes vary in terms of construction and size. They have evolved from crude gliders, which were open box kites large enough to carry a person to the enclosed fiberglass resin sailplanes, which we see today. In early times flights of 50 kilometers were hailed as a triumph, whereas today a flight of 50km is considered routine.

What is a sailplane?

Below is an early primary glider from the 1930's that can almost be defined as a sailplane.



The venerable L-13 Blanik (http://en.wikipedia.org/wiki/LET_L-13), an aluminum sailplane from the late 1950's which is still a basic trainer in Europe and many clubs in Canada.



This is the ASH25 (<http://www.easternsailplane.com/sailplane/ash25m.html>), a modern high performance fiberglass sailplane with a glide ratio of 57:1 almost double that of the Blanik and nearly 4 times that of the primary glider.



In the old days we used winches or bungee to launch gliders and sailplanes off the sides of a hill. Today we still use winches but aero tows are more common. A small powered aircraft tows the sailplane upwards using a 200' long polypropylene rope, about 3/8" thick. Once the planes reach 2000' (the common height for release) the sailplane releases the rope and begins what is generally referred to as "free flight".



Landing an airplane is the same, whether you have an engine or not, but in soaring you only get one shot at it!! Most pilots use a circuit to align themselves with the runway they want to land on. They fly parallel to the runway (downwind leg), then turn across the end (base leg), and then turn final and begin their approach. As the sailplane is already descending the pilot only has to modify his decent rate using dive brakes or spoilers. The pilot has to correct for drift due to crosswinds and once done the pilot will flare the plane

and then touch down onto the runway. Momentum ensures that the plane rolls evenly on its main wheel. Only when the plane stops rolling does a wing gently touch the ground.

What is soaring?

Soaring is motor less flight, using a sailplane and natural occurring atmospheric phenomena, called "LIFT", to gain altitude and stay aloft.

Lift in the atmosphere occurs in three primary forms. Thermals are by far the most prevalent of lifting sources available to the soaring pilot. The heat of the ground radiating upwards to the air directly above generates them. The heated air rises in a vertical column, almost donut shaped, and eventually reaches the condensation level of the air mass, and a cloud is formed. By circling inside this rising mass of air a glider pilot can gain altitude as quickly as 1000 feet per minute, and can reach heights of 8000 feet on a good day in Ontario. Flat farmers fields to mountaintops can generate thermals.



Ridge lift is another form of rising air. In this instance a prevailing wind rushes against a long hill or ridge of hills and the air is forced upwards over the hills. If the hills are high enough, and if the run of hills is long enough, great distances can be covered by the sailplane without ever needing to circle in lift. Essentially, once the airspeed required producing lift for the sailplane wings is produced, the excess airspeed is converted into extra height, or extra forward speed. In North America the best ridge is the Bald Eagle Ridge, which goes from Northern Pennsylvania into Tennessee. Distance flights of over 1000km have been recorded along this ridge.



Mountain Wave is the third form of lift used in soaring. If a strong wind blows over a row of mountains it may set up a sine wave in the atmosphere, much like water in a river passing over a pebble. The air in a mountain wave can rise or descend as much as 2000 feet per minute, and the phenomenon can exist up to over 50 000 feet of altitude. The current world record for an altitude gain was set in wave, and it surpasses 49 000 feet.

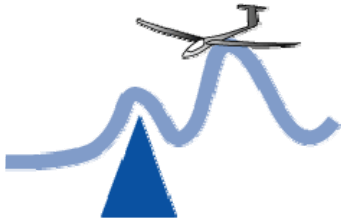

What so you do when the lift dies out and you haven't returned to the field? Typically the pilot makes an off field landing into a suitable field or airstrip. Modern gliders are designed to disassemble quickly with minimum effort and can be transported in a trailer by the pilot's retrieve crew.



Gliding is it considered a "sport"?

Soaring requires a high degree of mental fitness and physical endurance for contest and badge flying. The pilot must use great technical skill and knowledge of the elements to convert air movement into flight. Soaring can be highly competitive and be conducted as a team or individual effort. You be the judge!

Gliding - different from power flying?

What can the power pilot expect in differences from powered airplanes

You will undoubtedly notice fewer and some different instruments! For example the variometer, a sensitive rate of climb (vertical speed) indicator, can be quite sophisticated with an audio output and computer-controlled flight director. And the airspeed indicator is usually a 1½-revolution unit, with the low-speed end expanded. A flight director linked to a GPS unit may be used for navigation and flight recording. Take a few seconds to become familiar with the controls such as the winch cable or tow-hook release handle, dive-brake lever, and wheel-brake handle if fitted, and how close to the ground you are!

Keeping the wings level will be more of a challenge without the usual attitude instruments. In gliding more use of the horizon and relative position of the dash or canopy side rails is used to judge angle of bank. A yaw string replaces the turn and bank to coordinate your turns, which is necessary because of the long wingspan and effect of adverse yaw. More coordination with firm use of the rudder is required. Without an engine to control your approach gliders generally make use of powerful wing dive brakes or spoilers that let you control your rate of decent and glide ratio to make landing easy.

You may be asked to follow through on the takeoff and initial tow. As the flight progresses the instructor may allow you to try flying the glider, and you will probably feel it is rather difficult to keep good position behind the tow plane. If you launched by winch, the instructor will do the complete launch before letting you fly, as the climb attitude will be very unusual! In free flight you will be more at home. The glider is more often flown closer to its stall speed than is typical for power aircraft, and therefore its control response is slower. This is where the special airspeed indicator comes in handy, although speed control is best achieved by controlling the pitch attitude and not by *chasing the airspeed indicator!* At slower speeds, pronounced control movements are needed to fly the glider well. Before the approach and landing, you will notice the smaller circuit and the critical need to assess the effects of the wind and sink rate throughout the progress of the circuit as height steadily decreases. The instructor may allow you to follow through during the approach. The flare and the hold-off prior to touchdown will be much closer to the ground and more nose level than in a powered aircraft. Your pilot will do a normal held-off landing that is not a fully stalled landing. Continue to *fly* the glider as it rolls to a stop on its single wheel. One wing tip will then settle to the ground – that may feel strange if you are in a high-wing glider!

In your training in gliders, there will be many areas that likely were not covered in your power flying instruction. Keeping straight on the ground in crosswinds, flying slowly and accurately in thermals, selecting a field for a cross country off-field landing, emergency procedures for gliders, spin avoidance as well as full spins and other exercises are some of the items to be learned.

What's the downside of trying gliders if you have your PPL, CPL or ATR? You will likely find it too much fun and will want to make a habit of doing it!

Gliding Terminology

The "Big Parts" of a Sailplane

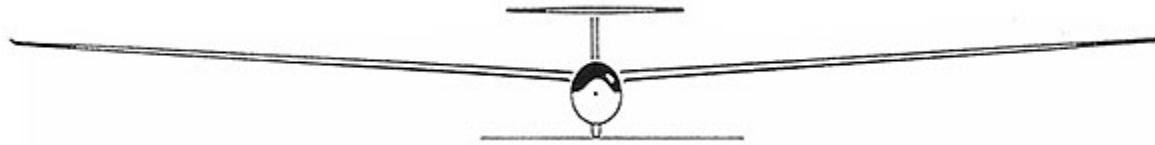

Above, beside and below are 3-view drawings of a modern sailplane. Although somewhat simplified, the drawings show the basic structure of a typical sailplane for the 15-meter class. There are many different racing classes of gliders, Standard Class (15m span, no flaps), 15 Meter Class (15m span with flaps), Open Class (Large meter spans, ranging from 15m to 25m and over), and the new World Class, which uses the PW-5, sailplane exclusively.

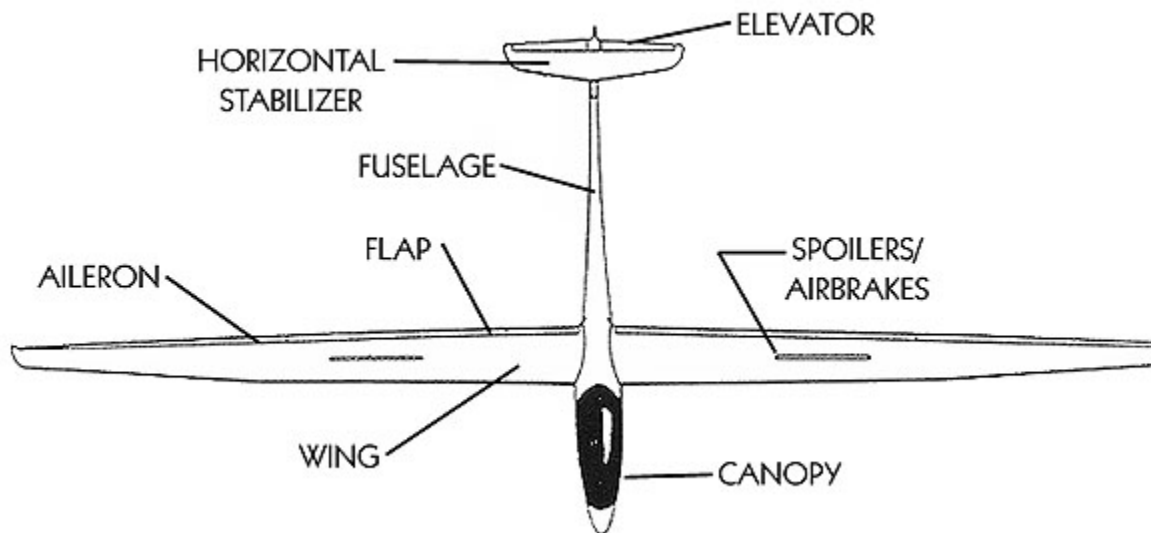
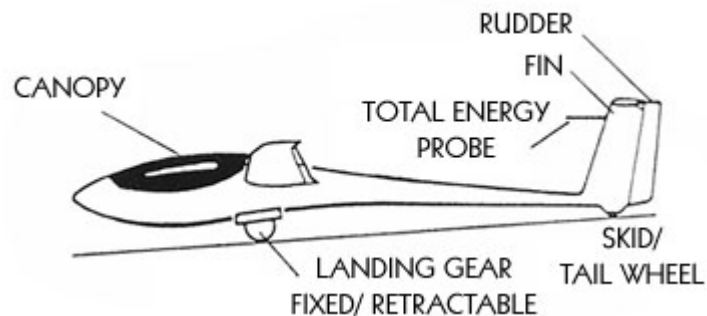

Instrumentation on each sailplane varies according to pilot preference, but each carries a minimum of altimeter, airspeed indicator, a magnetic compass, a variometer (a sensitive vertical speed indicator), and the "yaw string". Most pilots immediately upgrade their factory "vario" for a total energy system. Simply put, the total energy system allows the pilot to get a more accurate reading on the lift or sink surrounding the sailplane, but does not take into account "stick lift" or a vertical acceleration by the pilot like an uncompensated vario would. The most useful instrument by far is the yaw string. Attached to the outside of the canopy at one end, this 3 inch piece of red yarn shows the pilot the relative airflow of the glider. It works opposite to the more common "ball" found in powered aircraft. Glider pilots try to keep the plane co-coordinated at all times, but with large wings and ailerons on the planes, adverse yaw is a factor to be reckoned with. Glider pilots are forced to use the rudder pedals all the time to get the most from their plane. Of course, the most important instrument for all pilots remains on our body, the eyeball.



A Short History of Gliders

Leonardo da Vinci a 16 century inventor is believed to be the first illustrator of some of the first gliders. Germany's Otto Lillienthal is considered father of aviation. His observations of birds lead to the development of aerodynamics and gliders. The Wright brothers studied Lillienthal's books on flight and owe debt to his work. They made the first glider flights in North America.

In 1920's, because of treaty ban on power planes for the German military, glider pioneers there solved most of the modern glider structural issues. They also discovered how to use thermals and make 300-400 km flights. Later, Austrian "Kronfield" developed first usable variometer and started cleaning up at competitions. The Germans developed the lead in soaring theory & technology, which is retained to this day.

In WWII see more use of larger troop carrying gliders in combat. Germans used them in Invasion of Crete and the Allies in Invasion of Normandy on D Day. Post war many pilots looking for way to continue flying, improving economies and large numbers of skilled pilot creates boom in flying/gliding clubs

Soaring Association of Canada

The Soaring Association of Canada (SAC) is the national association for glider pilots in Canada. It was incorporated in 1945 and is a non-profit amateur sports association. The purpose of SAC is to promote, enhance and protect soaring in Canada. It does this by focusing on those matters, which cannot be handled effectively, or efficiently, by individuals, or gliding organizations, acting alone. Thus, it works with the aviation authorities on such issues as licensing and medical requirements, airspace, communications, aircraft certification, and various other technical issues, to ensure that the regulatory environment is consistent with the best interests of the soaring community. It provides a wide range of goods and services to its members including: an aircraft and airfield insurance plan, instructors' courses, training manuals, and related training and safety materials, publicity materials, and *free flight* - a bimonthly magazine on the Canadian soaring scene. SAC provides a link to the [Fédération Aéronautique Internationale \(FAI\)](#), an international body concerned with sport aviation and processing claims for internationally recognized achievements in soaring. The Soaring Association of Canada encourages soaring competitions. The SAC Website is www.sac.ca for more information about this organization.

Gliding locations in Canada

There are approximately 40 clubs and several commercial soaring centers in Canada. For detailed information, check out www.sac.ca under “SAC Services” and “clubs”.

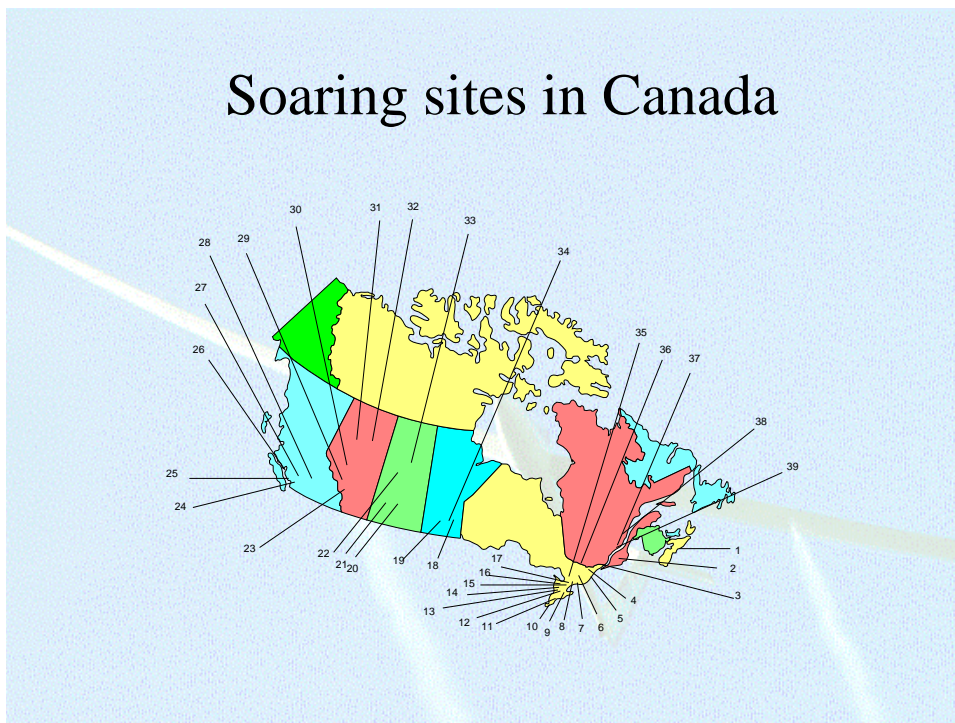

Gliding locations in the USA

Some favorite US locations for Canadian' soaring south of the border include Ridge Soaring - Pennsylvania <http://www.sac.ca/cas/hangarflying/ridgeprimer/gillespie1.html>, Seminole Lake-Florida <http://www.soarfl.com/>, and SOAR Minden –NV <http://www.soarminden.com/>.

The Regulations and Gliders

A. Licence Requirements:

http://www.tc.gc.ca/CivilAviation/Regserv/Affairs/cars/Part4/Standards/421.htm#421_24

421.24 Gliders - Requirements

(1) Age

An applicant shall be a minimum of sixteen years of age.

(2) Medical Fitness and Validity

(a) An applicant shall hold a Category 4 Medical Certificate valid for a pilot licence - glider.

(b) An applicant who meets the medical conditions specified on and signs the Civil Aviation Medical Declaration shall be deemed to have met the Category 4 Medical Standards.

(c) The medical validity period for the licence holder is 60 months.

(d) The licence is maintained by a valid Category 1, 3 or 4 Medical Certificate.

(3) Knowledge

An applicant shall have:

(a) Completed a minimum of 15 hours of glider pilot ground school instruction on the following subjects:

(i) *Canadian Aviation Regulations,*

(ii) Aerodynamics and Theory of flight,

- (iii) Meteorology,
- (iv) Airframes and Systems,
- (v) Flight Instruments,
- (vi) Navigation,
- (vii) Flight Operations,
- (viii) Emergency Procedures, and
- (ix) Human factors including pilot decision-making, and

(b) Obtained a minimum of 60% in the written examination Pilot Licence - Glider (GLIDE).

(4) Experience

(a) Within the 24 months preceding the date of application for the licence, an applicant shall have completed a minimum of 6 hours of glider pilot flight training, under the direction and supervision of the holder of a Flight Instructor Rating - Glider.

(b) The flight training shall include:

- (i) A minimum of 1 hour dual instruction flight time, and
- (ii) 2 hours solo flight time, including a minimum of 20 takeoffs and 20 landings.

(5) Skill

(a) Within the 12 months preceding the date of application for the licence, an applicant shall demonstrate in flight and on the ground familiarity with, and the ability to perform both normal and emergency manoeuvres appropriate to the glider used in the test and with a degree of competency appropriate to the holder of a pilot licence - glider.

(Amended 1998/03/23; [previous version](#))

(b) An applicant shall submit a letter from the holder of a Flight Instructor Rating - Glider, qualified on the method of launch for the glider used for the test, attesting to the applicant's satisfactory completion of the skill requirement.

(Amended 1998/03/23; [previous version](#))

(6) Credits

(a) Knowledge

- (i) An applicant who holds a pilot permit or licence in any other category of aircraft, except ultra-light airplanes, shall be deemed to have met 10 of the 15 hours ground school instruction requirement.
- (ii) An applicant who holds a pilot licence - aeroplane may be deemed to have met the ground school instruction requirement.
- (iii) An applicant who holds a pilot licence - aeroplane shall be deemed to have met the written examination requirement.

(b) Experience

An applicant who holds a pilot licence - aeroplane category shall have the total glider pilot flight training time reduced to a minimum of 3 hours, which shall include the minimum flight training specified.

B. Privileges of Glider Pilot Licence:

http://www.tc.gc.ca/CivilAviation/Regserv/Affairs/cars/Part4/401.htm#401_24

401.24 The holder of a pilot licence - glider may, under day VFR, act as

- (a) Pilot-in-command of a glider in which no passenger is carried on board;
- (b) Pilot-in-command of a glider in which passengers are carried on board where
 - (i) The glider is launched by a method of launch endorsed by the holder of a flight instructor rating - glider in the holder's personal log pursuant to [subsection 401.18\(1\)](#) or [\(2\)](#), and
 - (ii) The method of launch has been used by the holder for not less than three previous solo flights; and
- (c) Pilot-in-command or co-pilot of any aircraft for the sole purpose of the holder's flight training or flight test where
 - (i) In the case of flight training,
 - (A) It is conducted under the direction and supervision of a flight instructor qualified in accordance with section [425.21](#) of the personnel licensing standards, and
(amended 2001/03/01; [previous version](#))

- (B) No passenger is carried on board, and
- (ii) In the case of a flight test,
 - (A) It is conducted in accordance with [Section 401.15](#), and
 - (B) No passenger other than the person referred to in [paragraph 401.15\(1\)\(a\)](#) is carried on board.

Licences To Fly Gliders In Canada

A valid Pilot Licence or Permit – aeroplane/helicopters and medical can be used to learn to fly in gliders (CAR 401.26/22/27). The medical validity period for a glider licence holder is 60 months. Power pilots will need a total of 3 hours in gliders (minimum of 1hr dual/2 hrs solo) and 20 Solo flights along with a letter from a glider instructor stating they are competent in normal and emergency manoeuvres in gliders (CAR 421.24). Power pilots with a pilot licence - aeroplane will be credited with the ground school requirement and will not have to attempt the TC written exam “GLIDE”. A Pilot Permit or licence in any other category of aircraft (except ultralights) will be credited with 10 of the 15 hours required for ground school. The 5 additional hours of the ground school requirement not credited are to be used to study the glider specific information in the soaring training manual “SOAR” available at gliding clubs.

Cost of Training

In Canada almost all training takes place at gliding clubs. Instruction is usually free of charge; a student only pays for launches and rental of the glider. However, belonging to a club means paying a membership fee. Typical membership fees can be around \$500-\$1000 per year, but vary greatly between clubs depending on how they break down their expenses and the services they provide. Often clubs have block time on their gliders that members can purchase. Usually included in the club membership fee is your SAC dues, which provides the pilot with third party liability insurance and other SAC services. Also, SAC provides a high quality magazine, which is published once every two months and mailed to all members.

Clubs vary in size and structure, but everyone goes to the gliding club for the same reason, to fly. After taking an introductory flight you may decide to pursue your lessons in earnest. Your club's CFI (Chief Flying Instructor) will help you set up your agenda and find you the best instructor for your needs. From that point onward you will train until you are ready to solo, or fly by yourself (without the excess weight of the instructor in the back seat). An ab initio pilot can average around 40-45 flights to solo and a power pilot can average 10-12 flights or less depending on their experience and how often they fly. The cost per flight will vary but the average is around \$50-\$70 depending on the aircraft and tow method and club fee structures. After that you will get your license and hopefully pursue some personal goals, be they cross-country flight, instructing, or just flying around the club for fun!

Your glider license is just the beginning, and remember, it's a license to learn!

Passenger-Carrying

One of the privileges of a glider pilot licence is flying with family and friends. Gliding clubs will want you to gain some experience and will expect you to get a club check out flying from the back seat in the glider before they will ask you to fly prospective member on introductory flights. Some clubs restrict this function to instructors.

Section II

Motor Gliders General

There are a growing number of motorized gliders being purchased in Canada; these include self-launching gliders that have enough horsepower to be independent for take off. Some other motorized gliders have only enough power to sustain their flight or climb moderately (200 ft/min) after an assisted launch. The advantage is after a long distance flight if the lift deteriorates you can still return to the home field saving a requirement for a retrieve. The third class of motor gliders can be flown as a pure glider or powered airplane with flights of distances closer to ultralights (1000km). The more sophisticated motor gliders can cost between \$100,000 to \$250,000. Pilot skills are more demanding on these more complex machines and ratings are required for each different launch method including self-launching. The more complex gliders are often purchased by pilots who hold both a glider and a power licence. Flight Training and Safety has a recommended check out procedure in annex D of the Glider Instructors Manual Part B

Self-Launching

Typical self-launching gliders have the engine or propeller stowed after launch for the soaring portion of the flight. The engine is usually left stowed for the landing.



Sustaining

These gliders often appear similar to the self-launching glider. The engine usually of lower power to weight ratio is also stowed for soaring. The "Turbo" propulsion system is primarily intended to overcome dead air conditions and to avoid tedious retrieves - off-field landings may now be safely avoided. Secondly the "Turbo" also makes possible soaring safaris or, for instance, wave exploratory flights from places where launching facilities by auto, winch or aerotow exist.

http://www.mandhsoaring.com/duodiscus_T.html



Touring

Touring gliders may have the engine in the front or behind the pilot. The propellers may stow away or feather for soaring.



<http://www.pipistrel.si/planes/35>

APPENDIX D — TRANSITION TO MOTORGLIDERS

INTRODUCTION

Pilots progressing to sustainer engine (turbo), self-launching, or other motorgliders should obtain a thorough dual checkout in a similar glider before attempting solo flight. Pilots have had difficulty with these glider types, and the procedures in this appendix should normally be performed in a two-seat motorglider, but if none is available they should be performed solo. This Appendix has been prepared to provide guidelines for pilots transitioning to a sustainer engine, self-launching or other motor glider. Many of the older models have complicated starting procedures and can distract the pilot from the task of safely flying the 'plane. In addition, most of these sailplanes have poor performance when the engine is deployed but not operating. A series of flights and exercises have been devised therefore, to assist pilots to safely convert into their motorized sailplane. The pilot must become familiar with handling the aircraft under these emergency conditions before attempting a flight solo with the engine on. The initial airfield selected for this training should have a fairly long runway (4000 to 5000 feet) and has many off-field landing options close by. Learning on too short a runway will be difficult. This Appendix has been prepared to provide guidelines for pilots transitioning to a sustainer engine, self-launching or other motorized glider. It is hoped these guidelines will help pilots convert safely into engine takeoffs and emergency landings when first flying their new motorized glider.

GENERAL GUIDELINES

- Before using the engine for the first time, the pilot should become thoroughly competent at flying the glider without using the motor. This will require a number of soaring flights, launching usually by aerotow, during which the characteristics of the glider can be explored and mastered.
- Takeoff performance in a self-launching glider can be greatly affected by weight, slope of the runway, length/wetness of the grass, hard runway surface, wheel brake, density altitude, bugs on wings, etc. Before takeoff under the glider's own power, a physical landmark for a lift-off decision point must be selected to allow a safe abort. If not airborne by this point the takeoff must be aborted.
- Never attempt to deploy the engine and start it in the circuit. It is recommended that when planning to deploy and start the engine, circle over your selected landing field. Climb away while circling over the field until certain the engine is performing well.
- Do not deploy the engine in flight unless you have picked out a landable and reachable field with the engine out but not operating. Should the engine not start, you will need the field in short order.

- Once the engine is deployed and does not start by 800 feet agl do not continue to attempt a start or try to store the engine unless this is an automatic (one-button) action. Shift your concentration to completing an abbreviated circuit and landing with the engine extended. The downwind, diagonal and base legs will have to be much closer than normal to the intended landing area.

TRANSITION FLIGHTS

Training and checkouts in a two-seat glider

If a suitable two-seat glider with powerful airbrakes is available the pilot should first practice:

- Circuits with the airbrakes open sufficiently to simulate an open and wind milling motorglider engine producing a large amount of drag,
- Full airbrake landings, and
- The stall and speed recovery exercises described below.

The first stage is to permit the pilot to become familiar with the motorglider's performance and handling without the engine deployed, using another more familiar glider and launch method. This may take several flights. The preference for training and checkouts is with an instructor in a dual motorglider with similar performance to the solo motorglider. If a qualified motorglider instructor is not available then the pilot should perform a self-checkout in his motorglider after completing the above exercises satisfactorily in the two-seat (non-motor) glider.

Motorglider engine handling practice on the ground

The next stage will be to practice deploying, starting/stopping, and retracting the engine while on the ground. Some engines have very complicated procedures that require a checklist to ensure correct completion. Before moving on to the following stage, these skills must be mastered.

Motorglider handling practice with wind milling engine

The next series of flights are with the motorglider and will explore the glider's handling with the engine deployed but with a windmilling propeller. The aim is to simulate a launch failure on takeoff at a safe height, e.g. 3000 feet agl, and to determine the minimum safe height above ground that is needed to complete a turn back to the airfield. Using a familiar launch method, climb to a safe altitude for upper air work. Deploy the engine and complete the following two stages of exercises with a windmilling propeller:

- Perform a few stalls from a climbing attitude (simulating a normal climb with the engine operating). Recover from the stall to a normal gliding attitude and airspeed as required for the windmilling prop condition, and note the height lost. Note also the time taken to regain speed. Repeat a few times trying to recover with minimum height loss and minimum time to recover to a safe speed. To become fully comfortable with the stall characteristics, repeat this exercise on extra flights.
- The second stage for these practice exercises also involves the windmilling propeller (except with sustainer engines where an engine failure on climb-out will not be simulated). The exercise should be repeated several times to become fully comfortable with the maneuver. Dive to gain speed to above that for a normal climb (the pilot's handbook recommended climb speed). Transition into the normal climb attitude by pulling up. When the speed reduces to the recommended minimum climb speed, assume that the engine fails suddenly. Note the height and time. From this **simulated climb** recover promptly to an exaggerated nose-down attitude to regain a suitable approach speed as fast as possible. Note the height lost in this maneuver and the time taken to reach a safe maneuvering or approach speed. Only when this speed has been reached perform a 180-degree turn to simulate a return to the takeoff runway. Once on the reciprocal heading with wings level, note the height lost and the total time taken since the assumed engine failure to complete the maneuver. A height loss of 500 to 700 feet and 10 to 15 seconds is not uncommon.

** It is doubly important to recognize that **an engine failure low to the ground will require a landing straight ahead**, and that there is a dangerous height zone within which it is very important to lower the nose as quickly as possible to maintain airspeed. At the same time, if the nose is lowered too much, it may be difficult to avoid a very heavy landing. Pilots should therefore practice recoveries to simulate this situation, noting the minimum height required to regain adequate speed suitable for an immediate normal held-off landing with the engine wind milling. Repeat the exercise for a 10-knot headwind, noting the time taken to reach the higher approach speed and total height lost. This will allow calculation of the absolute minimum height above ground that would be required to return to the airfield and to complete an engine windmilling, downwind landing following an engine failure on the climb out. Below this height the pilot *must* land the glider straight ahead.

Motorglider landing practice with windmilling engine

The next series of exercises are to practice landings with the propeller windmilling. Be prepared to execute an abbreviated circuit, as the rate of descent will be high and the approach path much steeper than normal. Once the pilot is comfortable with landing and judging the circuit with the engine windmilling, the exercises can move on to the takeoff (if solo training) practice stage.

Motorglider takeoffs

Practice the takeoff and be prepared for trim changes created by the propeller thrust. Engine speed control will be important and the climb angle with the more powerful engines may be impressive! For older self-launching gliders note that the takeoff run may be somewhat longer and the climb-out angle lower than for other launch methods, and this will depend of course on the engine power and propeller thrust plus effects of hard surface or grass, density altitude, etc. Therefore obstacle clearance on a short runway could be difficult. Takeoffs must be practiced first on a long runway before attempting shorter field takeoffs and landings. Be prepared for launch interruptions on takeoff and have your Options predetermined as part of the pre-launch CISTRSC-O, and the glider and the pilot's personal pre-takeoff checklists.

Lastly, partial loss of engine power or thrust must be treated as an engine failure, and a safe speed recovered before turns are attempted. If the glider is below the absolute minimum height above ground required returning to the airfield, the glider must never be maneuvered into a 180-degree turn, but a field ahead should be used for an emergency landing with the windmilling prop.

There is a Flight Training and Safety Committee document with recommendations how to help transition to Motor gliders and some good American literature on the SSA web site.

Section III

Glider Cross Country Flying

Cross-country soaring is the most challenging aspect of flying that exists. Many pilots "give up" the sport of soaring before they achieve a level of competency that allows them to try cross-country. They may have been told about it, but they didn't understand it. To explain to a nonbeliever that you are confidently going to release from tow, travel several hundred miles and then triumphantly return home that evening is too difficult for most people to imagine. But, since you are reading this page, you are obviously aware of this, nearly exotic, form of adventure.

Everyone is a "student" when it comes to cross-country. We never stop learning.

As ground based mortals, we are attempting to pit ourselves against the forces of nature (which includes winds, sun, clouds, and gravity) in an effort to travel from one location to another, while traveling in the atmosphere. Granted we must employ a lot of technology to accomplish this feat, but large degrees of higher technology in the form of sophisticated equipment are not as important as a slight increase in knowledge and skill of the pilot. The first step after licence is to start your Bronze badge training. Here you will receive you basic skills and club authorization to start soaring cross-country.

The Canadian Advanced Soaring is group of soaring enthusiasts who support cross country soaring and contest flying and provide a web page and training seminars.

<http://www.sac.ca/cas/homepage/casintro.html>



Section IV

Badge Flying

In the soaring community badge flying is controlled internationally by FAI and administered by SAC. The intention of badges is to recognize achievement and challenge pilots to develop their skills beyond the licence stage. It is possible at many club locations to complete 500 km flights. Several 1000 km flights have been completed in Canada at exceptional soaring sites. Wave or ridge lift is usually involved in the longer flights. A total of 275 have been completed in the world. Certified GPS and data loggers are typically used to prove distances traveled. The current world records are a max height of 14,938 meters, three turn distance of 2,049 km, and average speed over 100 km distance of 217 km /hr.

Typical Gliding Badges:

“A” Badge - first solo

“B” Badge - 5 min of sustained flight

“C” Badge - 1 hr flight after release

Bronze Badge - Cross Country requirements

Silver - 50 km, 5 hrs duration, 1000m climb

Gold - 300 km (plus Silver duration/climb)

Diamonds 300 km, 500km, 5000 m climb

1000 km distance

2000 km distance

Contest Flying

Gliders are raced in contests (Club, Provincial and Nationals) held each summer in gliding sites across Canada. Pilots fly as fast as possible around a course made up of GPS turn points. Gliders must fly over or into a certain radius from the turnpoint. Most competition gliders can fly up to 155 MPH with 47:1 glide ratios!

The Canadian Advanced Soaring Group exists to promote competition. Their website <http://www.sac.ca/cas/homepage/casintro.html> provides useful information for those interested in competitive soaring including an online soaring contest.

Gliders are raced typically in 3 classes in Canada:

- Standard** class (15 meter wingspan, no flaps)
- 15 meter** class (similar to Standard, but with flaps)
- Sports** class (different types of gliders, but handicapped to keep the race equal)



SECTION V

What does a typical glider circuit look like?

Gliders fly a similar circuit pattern to powered aircraft but the gliders glide ratio and surface winds must be taken into consideration. Therefore, gliders commonly fly a tighter pattern than powered aircraft. Gliders have one chance to get it right to land. Just imagine yourself in your Cessna and the engine goes silent. What would your pattern look like? One would imagine it would be tighter than a typical glider. Below is a typical glider circuit.

Glider Circuits

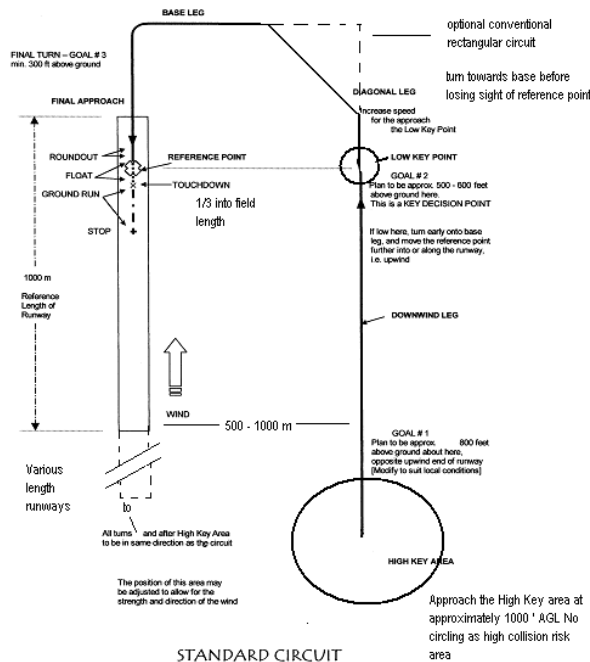

Freedoms Wings

Freedom's Wings Canada provides people with disabilities the opportunity to fly. The program strives to improve the quality of life of persons with disabilities by providing a physically and intellectually exciting and challenging introduction to flight. The purpose of Freedom's Wings Canada is to bring the world of soaring to disabled persons by:

- Exposing persons with disabilities to the soaring experience
- Teaching qualified persons with disabilities to soar
- Providing facilities for soaring to those persons with disabilities able to soar
- Providing training for instructors, ground crew, and flying students
- Providing a non-profit educational and fraternal organization
- Serving as a resource and model for other organizations with similar intent

Some gliders are fitted with adaptive hand controls to permit someone with lower limb disability to control the glider. Several Chapters are located across Canada and more

information is available at the Freedoms Wings website:
<http://www.freedomswings.ca/fw/>



Section VI

Becoming a Tow Pilot

Most gliding clubs conduct their own tow pilot training and are looking for tow pilots. This is done under the supervision of the club's Chief Tow Pilot who will "sign off" on the club qualification and conduct the annual refresher training. There is no minimum requirement in CARs for towing gliders. The one reference to towing is CAR 602.22 which specifies the requirement for a release hook and control.

http://www.tc.gc.ca/civilaviation/Regserv/Affairs/cars/Part6/602.htm#602_22 .

There is a section on banner and glider towing that you should be familiar with the aviation advisory circular which addresses tow plane operation (<http://www.tc.gc.ca/CivilAviation/certification/guidance/523/523-007.htm>).

Most clubs (but not all) operate tail draggers so you should have about 5 hours experience in tail draggers before you learn to tow. Few clubs provide this tail dragger training so you will have to check with the club where you plan to tow. Tow pilots are most often required to be members of the club and SAC as most are insured through the SAC insurance scheme. The following suggested qualifications will give you an idea of what clubs are looking for in general. However, Check with the club as their requirement may be more or less.

TOW-PILOT QUALIFICATIONS

- 1) An experienced glider tow plane pilot is a pilot having not fewer than 100 hours flight time as pilot-in-command on aeroplanes, including not fewer than 100 glider tow flights.

2) The pilot-in-command of an aircraft towing gliders should meet or exceed the following requirements:

(a) If a tow plane pilot holds a Glider Pilot License and has performed a minimum of five training tow flights under in-flight supervision by an experienced glider tow plane pilot, he should:

- i. hold a pilot license valid for aeroplanes,
- ii. have acquired not fewer than 45 hours pilot-in-command flight time in aeroplanes,
- iii. have not fewer than 5 hours pilot-in-command flight time on the tow plane type.
- iv. have a logbook entry certified by an experienced tow pilot including “skill level and experience satisfactory for towing gliders”.
- v. be thoroughly familiar with the operating limitations of the glider being towed and with necessary emergency procedures.

(b) If the tow plane pilot is not the holder of a Glider Pilot License but has performed a minimum of five training tow flights under in-flight supervision by an experienced glider tow pilot, he should:

- i. hold a pilot license valid for aeroplanes,
- ii. have acquired not fewer than 65 hours as pilot-in-command flight time in aeroplanes.
- iii. have not fewer than five hours pilot-in-command flight time on the tow plane type.
- iv. have a logbook entry certified by an experienced tow pilot including “skill level and experience satisfactory for towing gliders”.
- v. be thoroughly familiar with the operating limitations of the glider being towed and with necessary emergency procedures.

(c) If the tow plane pilot has not performed five training tow flights under in-flight supervision by an experienced tow plane pilot and does not hold a Glider Pilot License, he should:

- i. hold at least a Private License valid for aeroplanes,
- ii. have acquired not fewer than 100 hours pilot-in-command flight time experience, of which 25 hours may have been acquired in gliders, and
- iii. be thoroughly familiar with the operating limitations of the glider being towed and, with necessary emergency procedures.

END